



ПРОЕКТСОФТ

Software Package

Design Expert version 2.0

Plug-in for ZwCad 2011

Drawing of RC and steel structures

User Manual

All rights reserved

2011

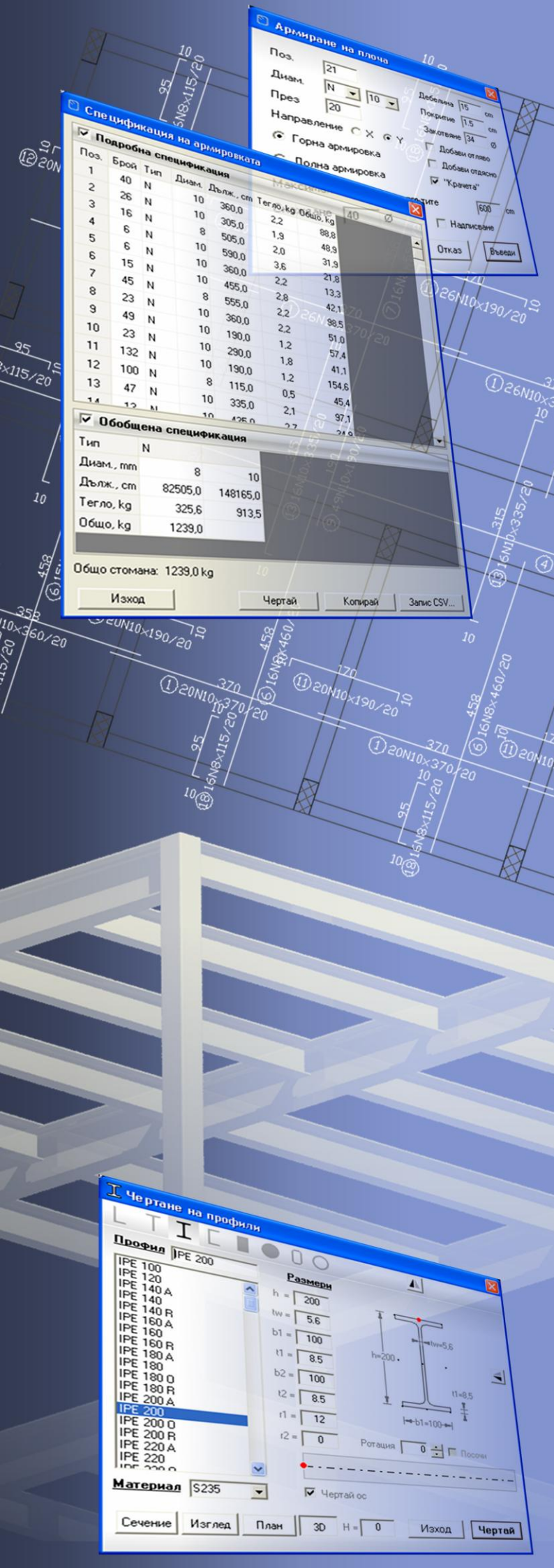



CONTENTS

ABOUT THE PROGRAM.....	3
Settings.....	3
REINFORCED CONCRETE STRUCTURES.....	3
Bends and hooks	3
Bar label.....	4
Link label.....	4
Draw bars.....	4
Insert bars.....	5
Bar arrangement zones	6
Draw S-link.....	6
Draw open link	6
Draw closed link	6
Draw double closed link.....	6
Draw bars in section	6
Bars in section along object	7
Bending schedule.....	7
Slab reinforcement.....	8
Openings (holes)	8
Design and draw beams	8
Draw columns	9
Draw shear walls	9
Design and draw foundation pads	9
Design and draw stairs	9
STEEL STRUCTURES	9
Draw steel elements.....	9
Assign steel sections	10
Draw steel sections	10
Draw main sections and elevations	10
Update drawing 2D/3D	10
Labels of steel elements	10
Steel bill of materials	11



About the program

Design Expert Plug-in for ZWCAD 2011 is created for drawing of reinforcement details and steel structures with ZWCAD 2011. Commands can be started using the „Design Expert” menu, toolbar or the command line. Commands for labels and specifications are consistent with reinforcement output from other Design Expert modules for beams, columns, shear walls, foundations and stairs.

Settings

Command: DEXSET, DXS

Displays a dialog with basic program settings. Always start with this command first. Enter final text size on printed drawing in “Printed text size” box in [mm]. Actual text size in the drawing is calculated automatically depending on specified units and drawing scale. For example, actual text size for displayed settings on right will be $2.5 \cdot 50 = 125$ mm.

For reinforcement drawings select units to be [mm] or [cm] and for steel drawings select [mm].

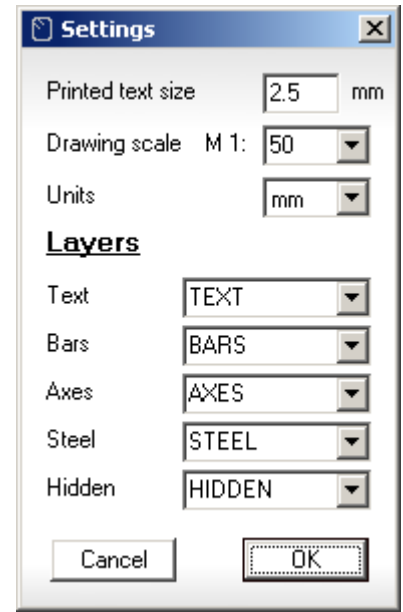

Reinforced concrete structures

Bends and hooks

Command: BARROUND, RN

Appends bends and hooks to the selected bars. Bars should be defined as polylines.

You can select objects before or after you start the command. Then enter the following data in the command line:

Bending radius <>:

For precise drawing you should enter the radius at centerline r_o which is greater with $0.5 \cdot \emptyset$ than mandrel radius r_m . Recommended radiuses are given in the following table:

Code	NPBStBK		Eurocode 2	
\emptyset	<12	≥ 12	≤ 16	> 16
r_m	1.25 \emptyset	2.5 \emptyset	2.0 \emptyset	3.5 \emptyset
r_o	1.75 \emptyset	3.0 \emptyset	2.5 \emptyset	4.0 \emptyset

Hook length (0 – no hooks) <>:

Hook angle (0°, 45°, 90°) <>:

Default value is displayed in brackets <>. Press **Enter** to use the default value.

If you have selected bars preliminary, hooks are added to both ends of each polyline and the command is completed. If you have not, you are prompted to

Select Object:

Click a polyline closer to the end where you would want to have a hook. That is how you can add a hook only at one side. You can continue with other polylines until you press **Esc** or click in empty space.





Bar label

Command: BARTEXT, BTE

With this command you can input bar data such as mark, count, type, diameter and spacing for selected bars. Dimensions can be optionally drawn as well. Bar length is calculated automatically. Reinforcement area „As” is calculated and displayed for information.

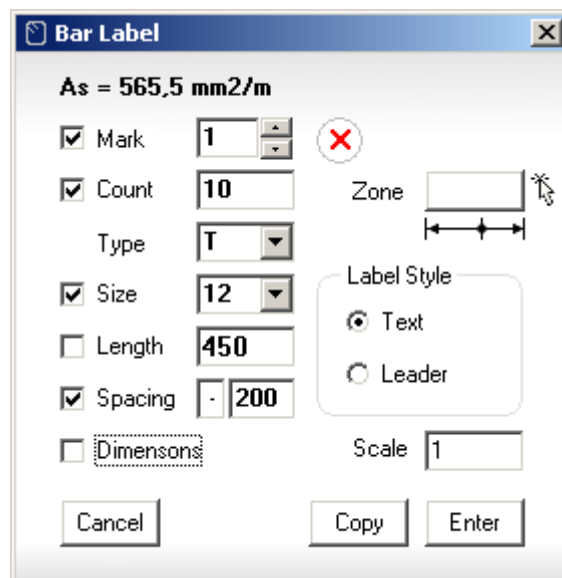
Bar data is stored into the selected polylines. When a data field is empty, current data from the polyline is used. The **X** button clears all fields. If you want to refresh labels without changing data, clear all fields and click **“Enter”**. That is how you can refresh lengths and counts after polylines modification. If you want to copy bars, copy polylines only and use the command to create the labels.

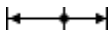

Bar count is calculated automatically when you specify arrangement zone  and spacing. Click the  button to specify the zone. You are prompted to select two points. Zone length is taken to be the distance between both points. Then you are prompted to confirm if the zone object is created. With „Object” option you can attach an existing zone to the bar (see „Bar arrangement zones”). You are prompted to select an object. If you select a line or a polyline, only length is taken. Zones are actually connected to the respective bars and count will be updated when you modify the zone object. Count is equal to zone length/spacing + 1. Count will also change if you modify spacing. If you do not want that, switch the zone button off.

You can select what data will be included in labels by the respective checkboxes. With the **“ Dimensions”** checkbox you can select if bar dimensions are drawn or not. You can specify a scale factor for dimensions and lengths. For example, if a bar is scaled twice, you should specify a scale factor **„x0.5”** in order to get the actual dimensions.

After you have entered all data, click the **“Enter”** button to draw or update labels. With the **“Copy”** button you can export bar and label to another location. This is used when you draw bars in sections (e.g. for columns, beams etc.).

Link label

Command: LINKTEXT, LTE

Command is similar to previous, but only general dimensions for width and height are drawn instead of all straight segments.

Draw bars

Command: BARDRAW, BD

Draws a bar with arbitrary shape as a polyline, adds hooks and bends and displays the **“Bar label”** dialog.

When you start the command you are prompted to enter a point:

Start point [Offset <>]:



With the "**Offset**" option (**O**) you can specify offset distance. Current value is displayed in brackets <>.

Enter offset distance [Pick] <>:

Enter distance or type "**Pick**" (**P**) to pick the distance on screen.

Distance first point:

Distance second point:

Then you return to the beginning.

Start point [Offset <>]:

Enter a point.

Next point [Undo/Close]:

Enter next point and continue until you draw the polyline. Press "**Enter**" or right click to stop. Polyline is drawn parallel to the picked sequence of points at the specified offset distance. It is very convenient to specify distance to be equal to concrete cover and draw along concrete edge. Bar will be drawn inside the concrete. After that enter

Bending radius <>:



Rounds are added and the "**Bar label**" dialog is displayed. See " **Bar label**" topic for details.

Insert bars

Command: BARINSERT, BI

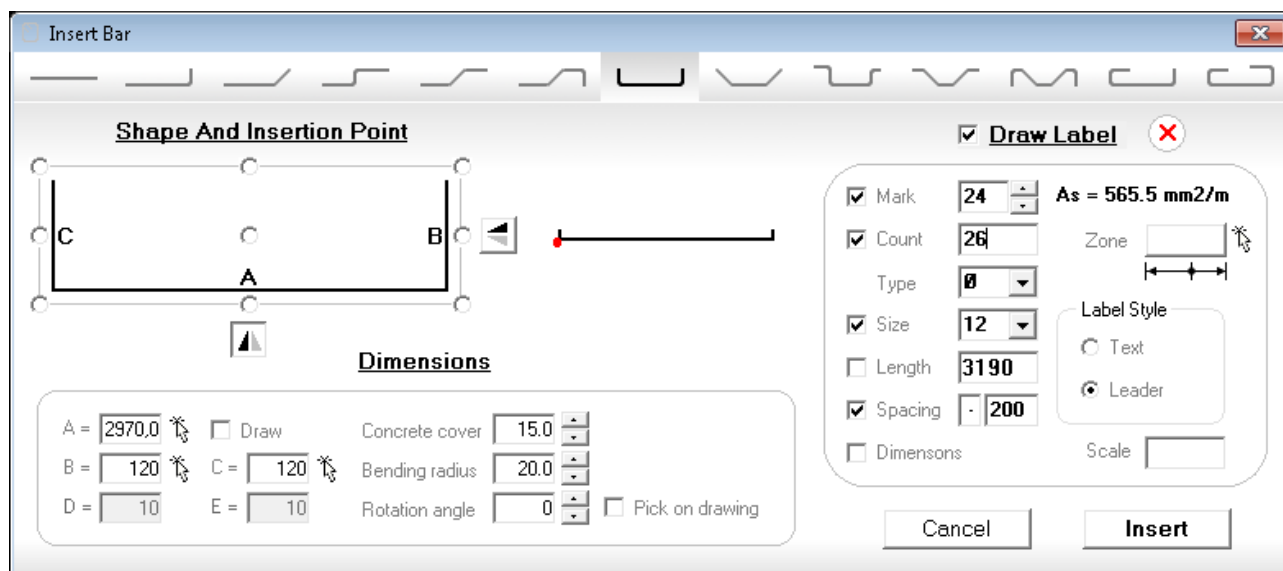
Inserts a standard bar into the drawing. The following dialog is displayed when the command is started:



Select bar shape from the toolbar on the top. Below is a bar scheme where dimensions "**A – E**" are indicated. Select an insertion point using option buttons  on the scheme. Enter values for "**A – E**" in "**Dimensions**" box as well as concrete cover, bending radius and rotation in plan. You can pick a dimension directly from the drawing with the respective  button. Concrete cover is automatically extracted so you can pick on concrete edge for your convenience.



Select the **Draw Label** checkbox to add a label to the bar. Data is entered in the same way as the „**Bar label**“ command.

When you are ready with the required data, click the **Insert** button and select insertion point. If **Draw** is checked for dimension **A**, you should specify second point to define bar right end. Dimension **A** is calculated from the specified points. If **Pick on drawing** is checked for rotation angle then rotation is defined by the specified points as well.

Bar arrangement zones

Command: BARZONE, BZ

Draws a bar arrangement zone. Enter first and second point and select bar(s). Zone is represented by dimension line and circle at intersections with bars. Bar count is calculated automatically. Zone is attached to bars and you can update bar count using **Bar label** command each time when the zone is modified.

Draw S-link

Command: LINKDRAW1, SD

Draws S- shaped shear links. When the command is started you are prompted to enter:

First point [Cover<>/Radius<>/Hooks<>/Angle<>]:

Type „**C**“ (Cover), „**R**“ (Radius), „**H**“ (Hooks) or „**A**“ (Angle) to change, respectively, concrete cover, bending radius, hooks length or hooks angle. Current values are given in brackets <>. Enter first and second points on concrete edge. Concrete cover is extracted automatically from total length. Then link is drawn and the labeling dialog appears. Click **Copy** instead of **Enter** if you want to copy the link to another location.

Draw open link

Command: LINKDRAW2, LDO

Command is similar to previous, but you should specify the opposite corners of the section.

Draw closed link

Command: LINKDRAW3, LDC

Command is similar to previous.

Draw double closed link

Command: LINKDRAW4, LDD

Command is similar to previous.

*** **Draw bars in section**

Command: BARSECTION, BS

Draws a sequence of circles with specified diameter and spacing along path defined by the user. Command requires input of diameter, spacing and sequence of points as follows:

Bar size <>:

**Bar spacing < > or [Count]:**

If you type „C” (Count), you can enter total count for each straight segment and spacing is calculated from segment length and count. Then proceed with:

Start point:**Next point:**

Circles are drawn in the specified segment. You can continue drawing segments until you press „Esc” or right click to finish.

**Bars in section along object**

Command: BARDIVIDE, BD

Draws a sequence of circles with specified diameter and spacing along path defined by selected objects. This command works as follows:

Select Objects

Select single or multiple objects and press „Enter” or right click to continue. You can select different types of objects such as lines, polylines, arcs and circles.

Bar size <>:**Bar spacing <> or [Count]:****Bending schedule**

Command: BARSCHEM, BSC

Automatically calculates and draws reinforcement bending schedule and bill of materials (BOM). All reinforcement should be drawn as polylines in the respective layer as defined in „Settings”. Bar data should be assigned to all polylines using the „Bar label” command.

When the command is started you are prompted to select objects. All objects that do not satisfy the above criteria are filtered out. Objects are highlighted so you can check if your selection is correct. Then press „Enter” or right click.

The program collects bar data and builds the schedule. It compares data and when it finds different bars with same marks it fixes them automatically after user confirmation. You can miss bar marks completely when drawing and the program will number them for you in the end.

Bending schedule and BOM are

Mark	Count	Type	Size, mm	Length, mm	Weight, kg	Total, kg
25	110	Ø	8	6000.0	2.4	260.4
26	16	Ø	8	4275.0	1.7	27.0
27	16	Ø	8	925.0	0.4	5.8
28	23	Ø	8	1600.0	0.6	14.5
29	26	Ø	10	5950.0	3.7	95.4
30	67	Ø	10	6000.0	3.7	247.8
31	26	Ø	10	4850.0	3.0	77.7
32	41	Ø	10	1850.0	1.1	46.8

Type	Size, mm	Length, mm	Weight, kg	Total, kg
Ø	8	10		
		780000.0	758650.0	
			307.8	467.7
				775.5

Total reinforcement: 775.5 kg

Buttons: Cancel, Draw, Copy, Save CSV...



presented in tables. Click the "**Draw**" button to insert the tables into the drawing at selected location. The "**Copy**" button sends table contents to system clipboard and you can paste it into other programs. The "**Save CSV...**" button writes a *.csv file and opens it with the default application (e.g. MS Excel).

Slab reinforcement

Command: PLATE, PLA

Automatically fills arbitrary outlines with uniform reinforcement mesh with selected bar size and spacing. Outlines should be defined as closed polylines. They could represent separate spans of ribbed slabs, outlines of flat or foundation slabs or partial zones with additional top or bottom bars. Start the command and select outlines. Input dialog appears on screen.

You should enter start bar number, bar size and spacing, direction X/Y, position top/bottom, concrete cover and anchoring length.

If „ **Lengthen left/right**“ is checked, bars are lengthened outside the selected outline by anchoring length. This is used to provide additional anchorage at supports or beyond the zone where reinforcement is theoretically required.

You can also specify limit bar length which is possible to be delivered/produced. If outline dimensions are greater than limit length then several bars are lapped to fill the outline.

If you want labels immediately, you can check „ **Labels**“. If you are going to modify the reinforcement, uncheck this setting. You can always add labels with "**Bar Labels**" command. Check „ **Zones**“ setting to add arrangement zones.

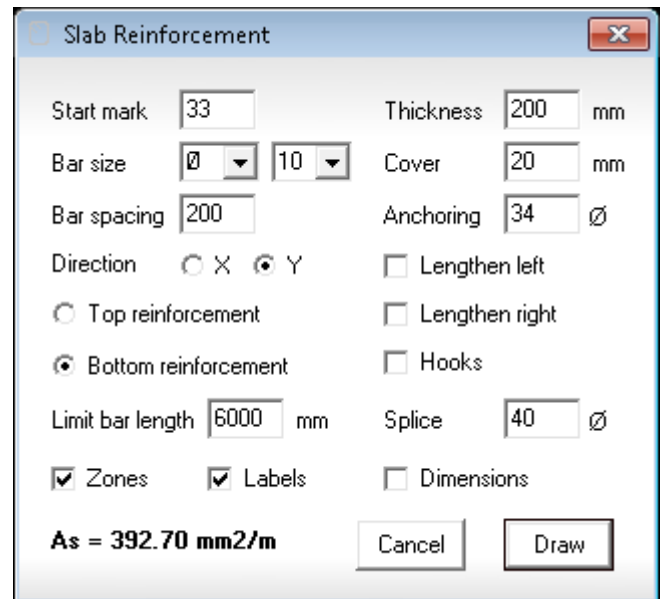

Openings (holes)

Command: HOLE, HO

Draws reinforcement details around openings. You are prompted to select two opposite corners of the opening:

First corner [Object]:

Second corner:

Press „**O**“ (Object) to select hole outline from the drawing. It should be defined as closed polyline.

A settings dialog appears on screen.

Anchorage should be measured outside the hole edge.

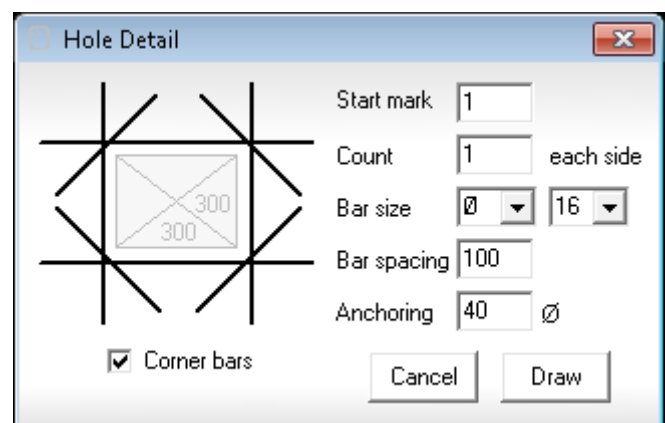

Design and draw beams

Command: BEAM, BE

Starts **BeamExpert.exe** application. For more information see [Beam Expert.pdf](#).



Draw columns

Command: COLUMN, CL

Starts **ColumnExpert.exe** application. For more information see [Column Expert.pdf](#).



Draw shear walls

Command: SHEARWALL, SW

Starts **ShearWallExpert.exe** application.



Design and draw foundation pads

Command: PAD

Starts **PadExpert.exe** application. For more information see [Pad Expert.pdf](#).



Design and draw stairs

Command: STAIR, STA

Starts **Stair Expert.exe** application.

Steel structures



Draw steel elements

Command: STEELDRAW, STL

This command is created for drawing of steel elements in 2D and 3D.

Select cross section type from the toolbar on top. List of standard sections are loaded on left and you can select one. Dimensions are loaded from corresponding text files, stored in „[.\\ZWCAD\\SteelShapes\\](#)” subfolder.

You can open these files with Excel and add or modify sections following the same format. Section name is filled in the “**Shape**” field. You can change it or you can add more

information like identification number, mark, etc. If section is not standard you can enter custom dimensions in the corresponding fields.

You can specify materials as well. Materials list is stored in file „[.\\ZWCAD\\Materials.txt](#)”.

You can draw elements in different 2D views: section, side, plan or 3D. You need to specify one point to insert a section and two points to define element axis for other views. If you have a vertical column in 3D you can input column height into the “**H=**” field. Then you need to specify only one point to insert the column. Red point indicates the alignment point which you will specify in the drawing. Section will be positioned relative to this point as shown. Click on scheme to change the alignment point. Use and buttons to mirror the section about the horizontal and vertical axis, respectively. For sections and 3D columns you may specify a rotation angle. If **Pick on drawing** is checked then you will be prompted for second point that will define the rotation angle. Click “**Draw**” to close

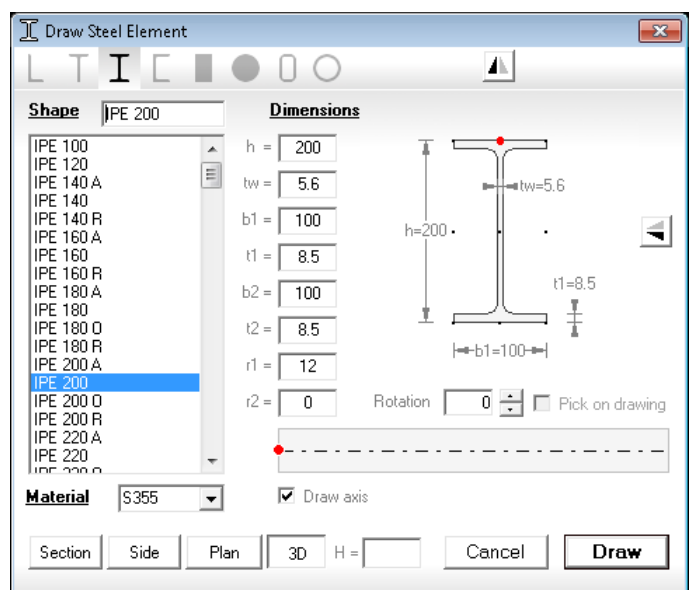



the dialog and proceed to drawing. Sections are represented by closed polylines, side and plan views are represented by parallel dashed and solid lines for the corresponding visible and hidden edges and 3D elements are drawn as 3D solids. Axis line is added and it has an important function – it contains element data used by all other commands. If you copy an axis alone, data is copied as well. Then you can use the „**Update drawing 2D/3D**” command to draw the element.



Assign steel sections

Command: STEELINPUT, STI

Assigns sections and materials to existing axes and draws elements in side view, plan or 3D. You can use this commands to modify elements sections and redraw them with the new section. Axes must be line objects in the respective layer (see “Settings”). Start the command, select objects and press “**Enter**” or right click. Data is entered into the same dialog as the “Draw steel elements” command.

You can draw a frame in 3D, export geometry to structural analysis software and calculate the required sections. Then you can assign them to the elements and generate automatic bill of materials and 2D structural plans and elevations using the commands bellow.



Draw steel sections

Command: STEELSECTION, STS

Draws sections of selected elements in a 2D drawing. You are prompted to enter two points. The line defined by these points should intersect the elements we need. Sections are drawn along the line at intersections with the respective elements.



Draw main sections and elevations

Command: STEELVIEW, STV

Automatically generates vertical sections and elevations out from a 3D drawing. You are prompted to enter two points that defines a window. Elements that will be shown in view should fit entirely into the window. Then enter an insertion point on left or right side. Elements that cross the window on the opposite side are drawn as sections.



Update drawing 2D/3D

Command: STEELUPDATE, SU

Automatically redraws selected elements that contain steel data. A 3D drawing can be converted to 2D one and all z coordinates will be set to zero. That is how you can generate 2D plans out of 3D models. You can create a 2D plan of a separate floor in multistory building. Just copy all elements from the floor including columns outside, select them and start the command.



Labels of steel elements

Command: STEELTEXT, STT

Automatically draws a label for each element that contains section name.



Steel bill of materials

Command: STEELBOM, STB

Automatically composes and draws bill of materials (BOM) for the steel elements created by the program. Drawing should be in [mm]. First, you are prompted to select elements axes. Then calculated BOM is displayed in a table. Click the "**Draw**" button to insert the table into the drawing at selected location. The "**Copy**" button sends table contents to system clipboard and you can paste it into other programs. The "**Save CSV...**" button writes a ***.csv** file and opens it with the default application (e.g. MS Excel).

You can generate BOM out of 2D and 3D drawings. Sections in 2D drawing will not be included.

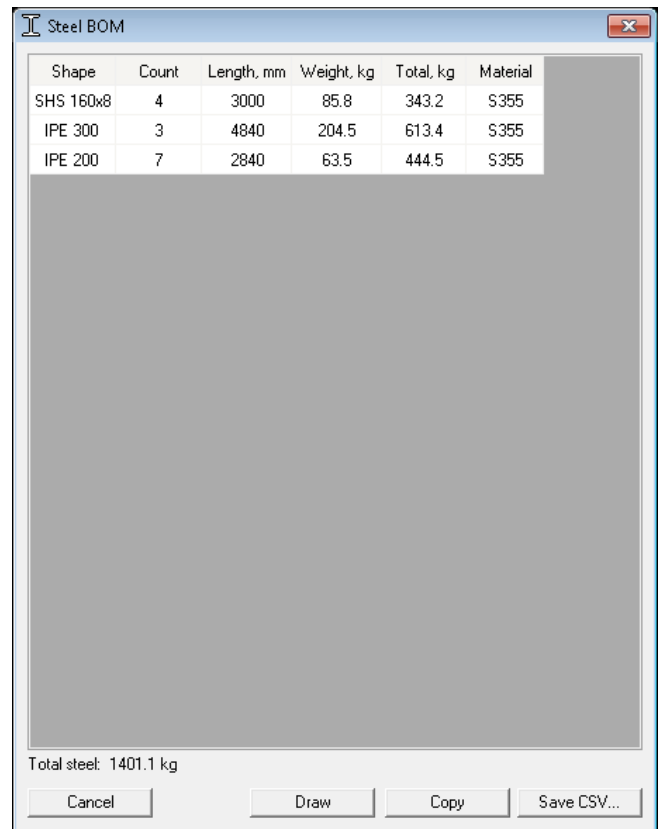

Shape	Count	Length, mm	Weight, kg	Total, kg	Material
SHS 160x8	4	3000	85.8	343.2	S355
IPE 300	3	4840	204.5	613.4	S355
IPE 200	7	2840	63.5	444.5	S355

Total steel: 1401.1 kg

Cancel Draw Copy Save CSV...